

N. CHASE.

Improvement in Folding-Stereoscopes.

No. 129,100.

Patented July 16, 1872.

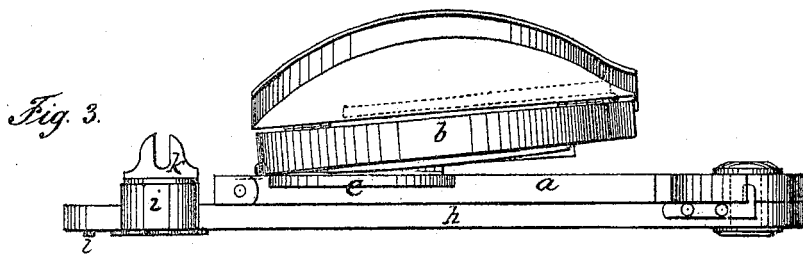
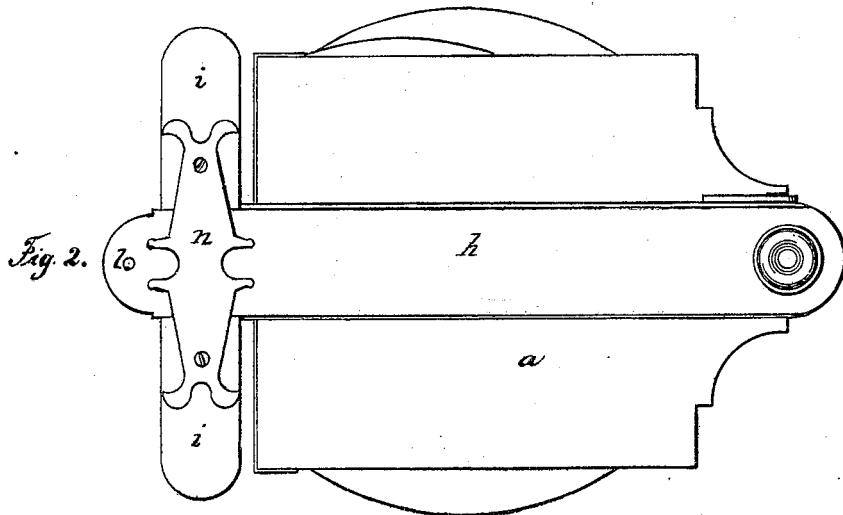
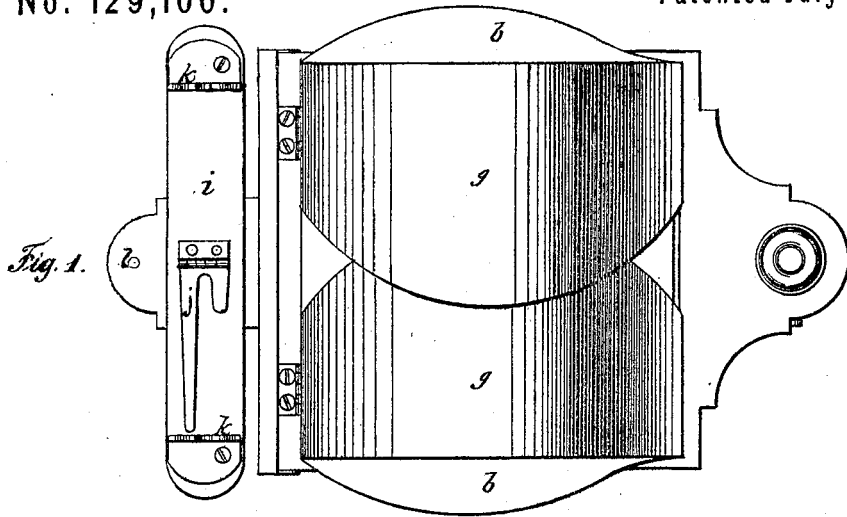

WITNESSES:

Herrn. Lauter.
M. Morris-Smith

INVENTOR:

Nelson Chase
 By his attorney
J. C. Robbins

N. CHASE.
Improvement in Folding-Stereoscopes.
No. 129,100. Patented July 16, 1872.

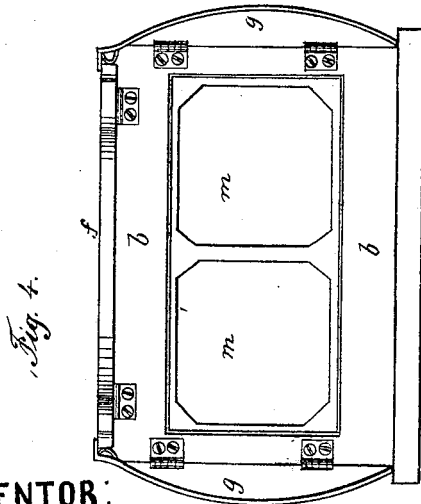
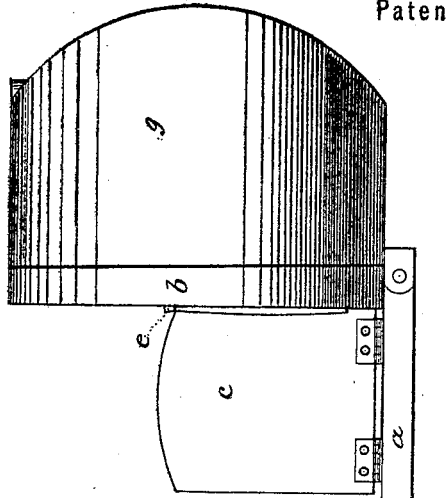
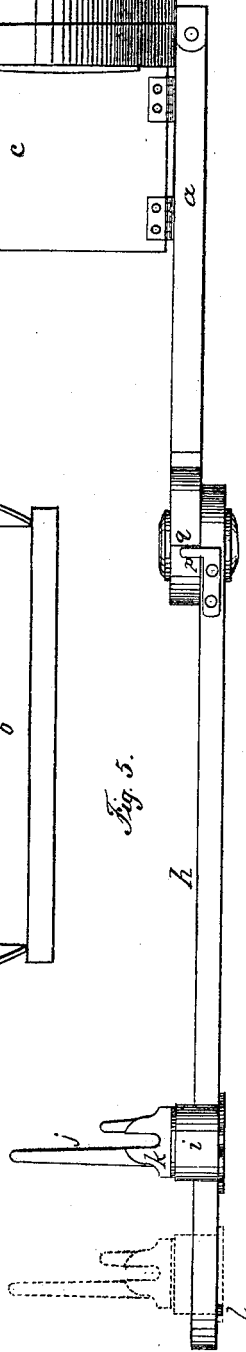

Fig. 5.



INVENTOR:

Nelson Chase
By his Attorney
J. C. Robbins

WITNESSES:

Thos. Sauter
M. Morris Smith

N. CHASE.
Improvement in Folding-Stereoscopes.
No. 129,100. Patented July 16, 1872.

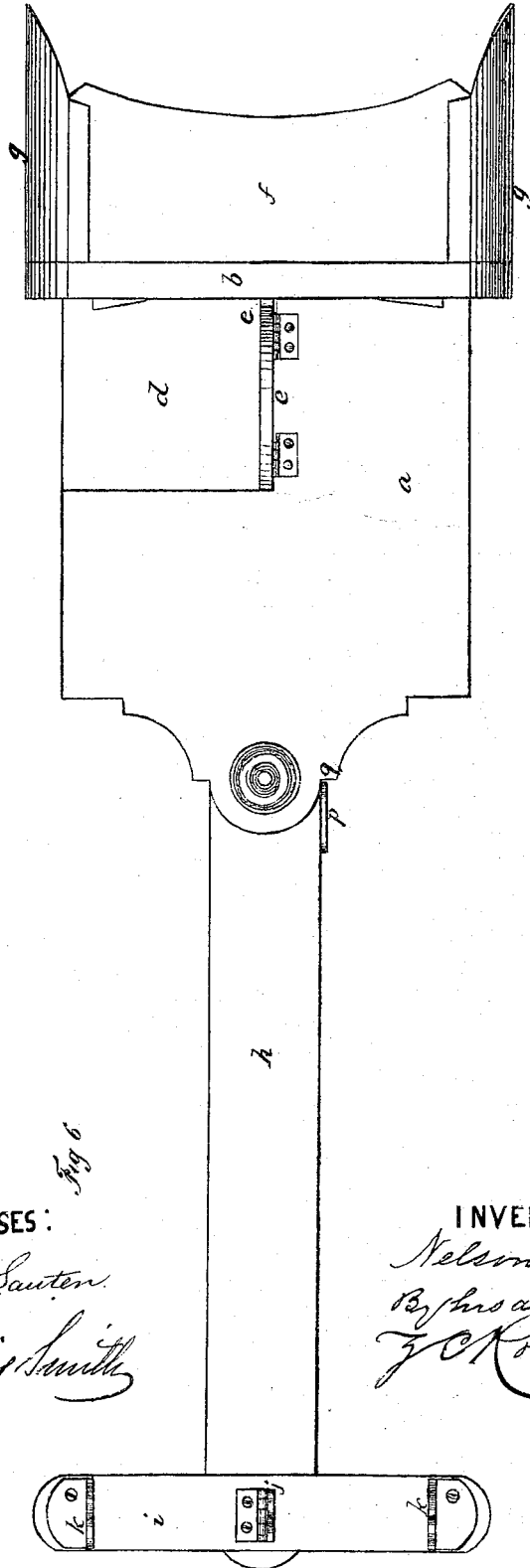

Fig 6

WITNESSES:

Henn. Sauter.
W. Morris Smith

INVENTOR:

Nelson Chase
 By his attorney
J. C. Robbins

UNITED STATES PATENT OFFICE.

NELSON CHASE, OF ENFIELD, NEW HAMPSHIRE.

IMPROVEMENT IN FOLDING STEREOSCOPES.

Specification forming part of Letters Patent No. 129,100, dated July 16, 1872.

To all whom it may concern:

Be it known that I, NELSON CHASE, of Enfield, in the county of Grafton and State of New Hampshire, have invented a new and Improved Pocket Stereoscope; and I do hereby declare that the following is a full and clear description thereof, reference being had to the accompanying drawing which forms a portion of this specification—

Figure 1 being a top view, Fig. 2 a bottom view, and Fig. 3 a side view, of said invention as it appears when it is compactly folded; Fig. 4 a front view, Fig. 5 a side view, and Fig. 6 a top view, of the same as it appears when it is extended to the proper position for use.

Similar letters indicate the same parts in the drawing.

The shape of the main section *a* of my improved pocket stereoscope is clearly shown in Fig. 2. The lens section *b*—the shape of which is clearly shown in Fig. 4—is hinged to the upper surface of the main section *a* at a point near to the rear edge thereof, so that when it is turned upward to the position shown in Figs. 5 and 6 the hinged edge of said lens section will rest upon the extreme rear portion of the upper face of said main section, as shown in Fig. 5. When the said lens section *b* is turned upward to the aforementioned position, the hinged diaphragm *c* is turned upward out of its recessed receptacle *d* in the upper face of the main section *a* (Fig. 6) to a right angular position to said face, in which position its rear edge will press closely against the projecting edge of the sash-strip *e*, which separates the lenses *m m*, and is firmly secured to the inner sides of the lens opening in the lens section *b*. Before turning upward the lens section *b* to the position shown in Fig. 5, the arm *h*, which is jointed to the front side of the main section *a*, must be turned outward to the position shown in Figs. 5 and 6; and before this can be done the picture-holding sliding cross-head *i* on said arm must be moved to its extreme outward position on said arm, shown in Fig. 6, and when it attains that position its further movement will be arrested by a vertically-projecting catch, *p*, (Figs. 5 and 6,) at the inner end of the left-hand side of said arm, striking against the shoulder *q* on

the main section *a*. A recess in the under side of the cross-head *i* receives the arm *h*, and it is retained therein by the metallic strap *n*, (Fig. 2.) A pin, *l*, projecting from near the end of the under side of the arm *h*, prevents the cross-head *i* from being detached from said arm. The picture-cards are held in position on the cross-head *i* by means of the notched lugs *k*, (Figs. 1 and 5,) secured near to each end of the face of said head, and the notched arm *j*, which is hinged to the central portion of said face in such a manner that it can be turned upward to the position shown in Fig. 5. Curved side-shades *g g* are hinged to the rear sides of the hinged lens section *b* in such a manner that said shades can be readily turned from the closed position shown in Fig. 1 to the open position shown in Figs. 5 and 6, and vice versa. The flat top shade *f* is hinged to the outer edge of the lens section *b* in such a manner that it can be readily turned outward to the horizontal position between the upper angular edges of the side shades *g g*, shown in Figs. 4 and 6, in which position it will be retained by the inward pressure thereupon of said side shades, and from that position the said top shade may as readily be turned inward upon the face of the lens section, and be covered over by turning the side shades inward thereupon, as shown in Fig. 1.

When it is desired to change the stereoscope from the open position shown in Figs. 4 and 6 to the closed position shown in Figs. 1, 2, and 3, the top shade *f* is turned inward upon the lens section *b*, and the side shades *g* are turned inward upon the top shade; the cross-head *i* is then moved to its extreme outer position on the arm *h*, and the arm is then turned around to the position shown in Figs. 1, 2, and 3; and when that position is attained, the cross-head *i* is pressed inward against the outer edge of the main section *a*.

I claim as my invention—

1. The combination of the main section *a* and the lens section *b* with each other, and with the pivoted arm *h* and the sliding cross-head *i*, substantially as and for the purpose herein set forth.

2. The combination of the main section *a* and the lens section *b* with each other, and with the pivoted arm *h*, the sliding cross-head

i, the lenses *m*, and the shades *f* and *g*, substantially as and for the purpose herein set forth.

3. The combination of the notched lugs *k* and the notched and hinged arm *j* with each other and with the sliding cross-head *i*, substantially as and for the purpose herein set forth.

In testimony that foregoing is a full and clear specification of my improved pocket stereoscope I hereunto subscribe my name this 17th day of May, 1872.

NELSON CHASE.

Witnesses:

E. J. DURANT,
H. C. BAKER.